



Northmace & Hendon<sup>TM</sup>

ESTD LONDON 1942

The World's Leading Supplier of Specialist Products  
for the International Hotelier

[www.northmace.com](http://www.northmace.com)

Based in the UK since 1942, we are the world's leading company  
in the design and manufacture of specialist hotel guest products.  
The originators of the Ironing Centre, the Welcome Tray and the Hotel Hairdryer.

With a reputation built on quality and customer care,  
we supply customers in over 100 countries  
from individual hoteliers to large Hotel Groups.

Our design philosophy: safety; functionality and simplicity of use;  
prevention of theft; longevity; and care for the environment.

## Regal Welcome Tray

Quite simply the best in the world

Product code: RWT



The image shows a black melamine welcome tray (A) containing a chrome cordless kettle (D), a compartmentalised ingredients dish (C), two white coffee cups on saucers, a French press, and a glass of water. The tray is set on a black base (B). Labels A-F point to the tray, base, ingredients dish, kettle, cups, and kettle lid respectively.

- A** Melamine lift-off tray to contain spillage, protect furniture and furnishings, and for guest convenience
- B** For excellent resistance against heat, stains and scratches, the base tray, lift-off tray and ingredients dish are all manufactured from Melamine.
- C** Compartmentalised ingredients dish for easy portion control and to aid guest selection
- D** Integral, quick boil, 1 litre, energy saving, cordless kettle with concealed element and indicator light
- E** Boil dry safety feature
- F** Easy for Housekeeping to clean inside kettle

Crockery and ingredients not supplied

5 years guarantee

Black / Chrome

## President Welcome Tray

Used in top hotels worldwide

Product code: PWT



The image shows a cream-colored melamine welcome tray (A) containing a cream-colored cordless kettle (D), a compartmentalised ingredients dish (C), two white coffee cups on saucers, and a white teapot. The tray is set on a cream-colored base (B). Labels A-F point to the tray, base, ingredients dish, kettle, cups, and kettle lid respectively.

- A** Melamine lift-off tray to contain spillage, protect furniture and furnishings, and for guest convenience
- B** Melamine base tray, lift-off tray and ingredients dish. (Melamine has excellent resistance against heat, stains and scratches)
- C** Compartmentalised ingredients dish for easy portion control and to aid guest selection
- D** Integral, quick boil, 0.8 litre, energy saving, cordless kettle with concealed element and indicator light
- E** Boil dry safety feature
- F** Easy for Housekeeping to clean inside kettle

Crockery and ingredients not supplied

4 years guarantee

Cream

# Welcome Trays

## Classic Welcome Tray

Chosen for its attractive design

Product code: CWT



- A** Lift-off tray to contain spillage, protect furniture and furnishings, and for guest convenience
- B** Ingredients displayed for easy portion control and to aid guest selection
- C** Integral, quick boil, 0.8 litre, energy saving, cordless kettle with concealed element and indicator light
- D** Boil dry safety feature
- E** Easy for Housekeeping to clean inside kettle

Crockery and ingredients not supplied

3 years guarantee

Black or Cream or White

## Elegance Welcome Tray

The favourite with hotels worldwide for its space saving and practicality

Product code: EWT

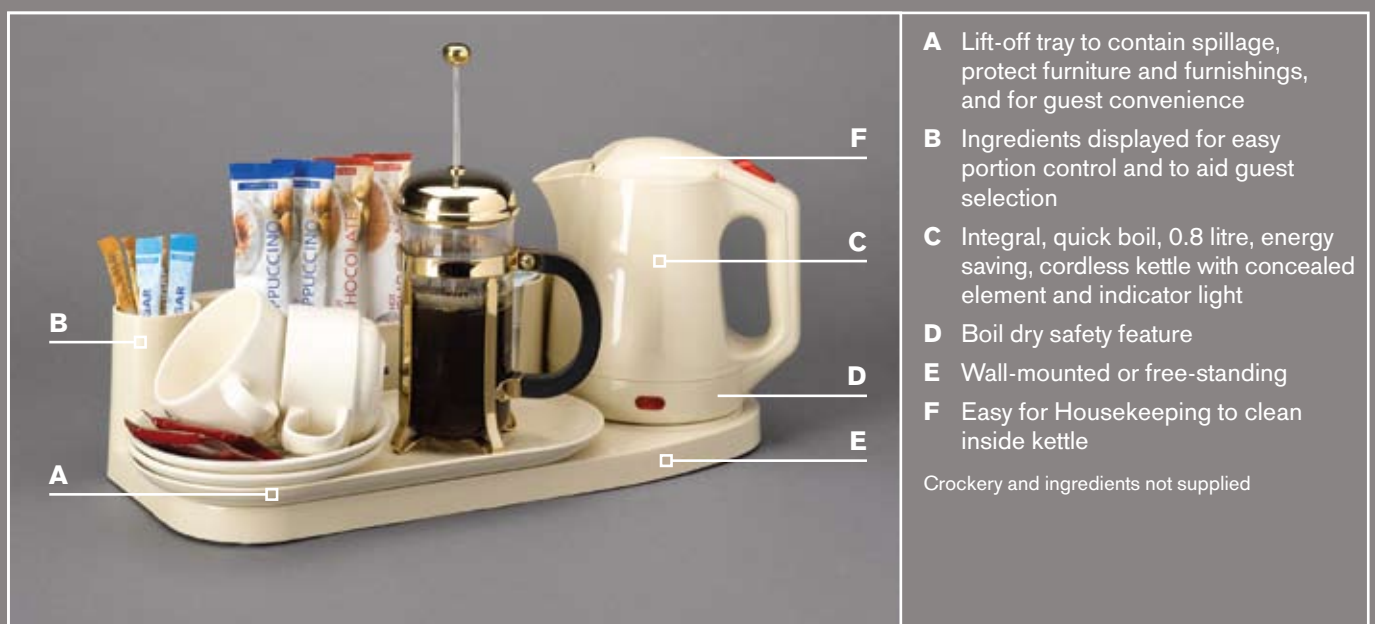

- A** Lift-off tray to contain spillage, protect furniture and furnishings, and for guest convenience
- B** Ingredients displayed for easy portion control and to aid guest selection
- C** Integral, quick boil, 0.8 litre, energy saving, cordless kettle with concealed element and indicator light
- D** Boil dry safety feature
- E** Wall-mounted or free-standing
- F** Easy for Housekeeping to clean inside kettle

Crockery and ingredients not supplied

3 years guarantee

Cream or White

## Standard Welcome Tray

Ideal for where space is at a premium

Product code: SWT



- A** Lift-off tray to contain spillage, protect furniture and furnishings, and for guest convenience
- B** Ingredients displayed for easy portion control and to aid guest selection
- C** Integral, quick boil, 0.8 litre, energy saving, cordless kettle with indicator light
- D** Boil dry safety feature
- E** Wall-mounted or free-standing
- F** Easy for Housekeeping to clean inside kettle

Crockery and ingredients not supplied

2 years guarantee

White

## Hendon Tray Set

A timeless classic – simply add the kettle of your choice

Product code: HTS

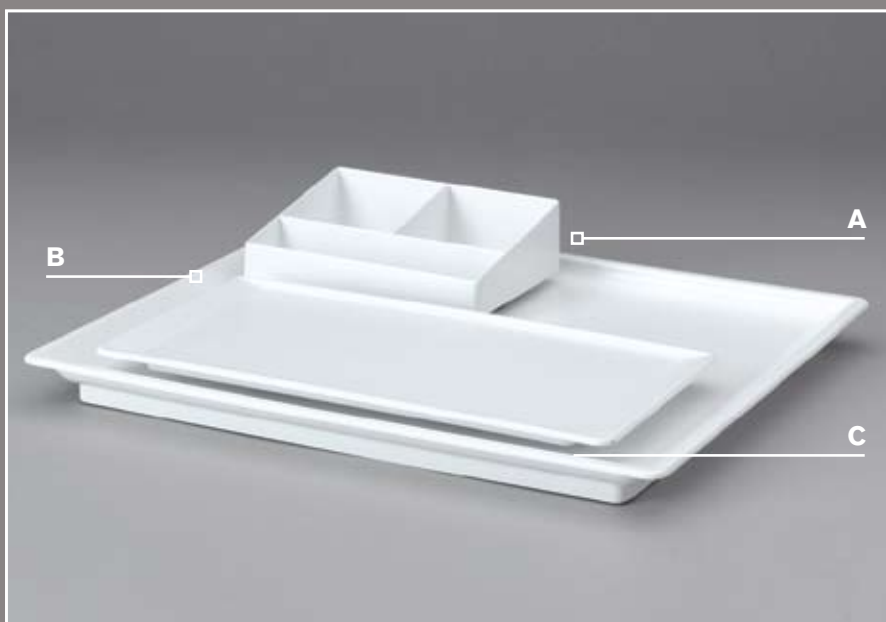

- A** 3 part set manufactured in tough ABS
- B** Base tray, lift-off tray and ingredients container
- C** Non-slip feet
- D** Versatile
- E** Suitable for use with all Northmace Hotel Kettles

3 years guarantee

Black or White

# Haircare

## Regal Hotel Hairdryer

Every luxury a guest could want

Product code: RHD



- A** Powerful 1850W
- B** Safety / economy “on-off” switch
- C** 2 fan speeds with 3 heat settings
- D** Anti-theft security wall holder
- E** Coiled cable
- F** Thermostatic cut-out to help prevent over-heating
- G** Complete with plug for simple and economic installation, no electrician required to fit (can if required be hard wired by a professional electrician)
- H** With optional concentrator and diffuser

5 years guarantee

Black / Chrome

## President Hotel Hairdryer

A beautiful hairdryer

Product code: PHD

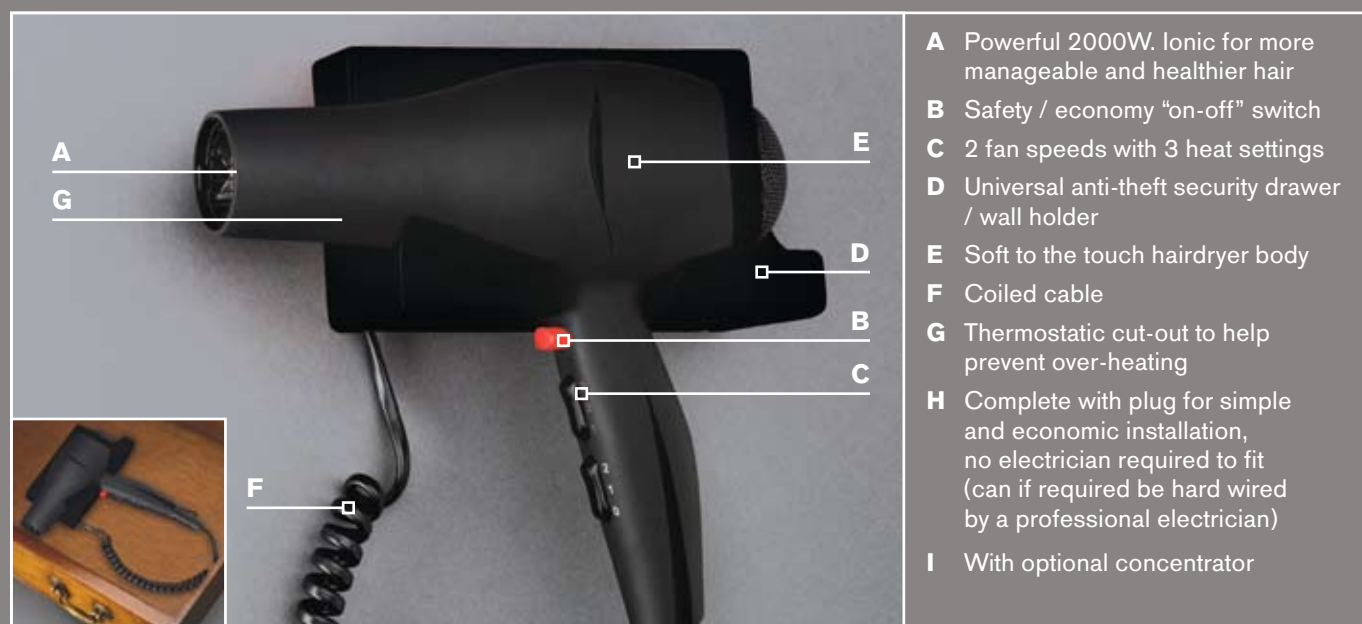

- A** Powerful 2000W. Ionic for more manageable and healthier hair
- B** Safety / economy “on-off” switch
- C** 2 fan speeds with 3 heat settings
- D** Universal anti-theft security drawer / wall holder
- E** Soft to the touch hairdryer body
- F** Coiled cable
- G** Thermostatic cut-out to help prevent over-heating
- H** Complete with plug for simple and economic installation, no electrician required to fit (can if required be hard wired by a professional electrician)
- I** With optional concentrator

4 years guarantee

Black

# Valette Elegance Hotel Hairdryer

A sleek modern design

Product code: VHD



- A** 1600W
- B** Safety / economy "on-off" switch
- C** 3 fan speeds / heat settings
- D** Universal anti-theft security drawer / wall holder
- E** With optional concentrator
- F** Coiled cable
- G** Thermostatic cut-out to help prevent over-heating
- H** Complete with plug for simple and economic installation, no electrician required to fit (can if required be hard wired by a professional electrician)

3 years guarantee

White or Cream

# Standard Classic Hotel Hairdryer

Space saving, versatile and reliable

Product code: SCHED



- A** 1200W
- B** Safety / economy "on-off" switch
- C** 2 fan speeds / heat settings
- D** Anti-theft security wall holder
- E** Coiled cable
- F** Thermostatic cut-out to help prevent over-heating
- G** Complete with plug for simple and economic installation, no electrician required to fit (can if required be hard wired by a professional electrician)

2 years guarantee

White

# Haircare / Ironing Centres

## Hotel Hair Straightener

The latest, stylish guest accessory

Product code: HHS

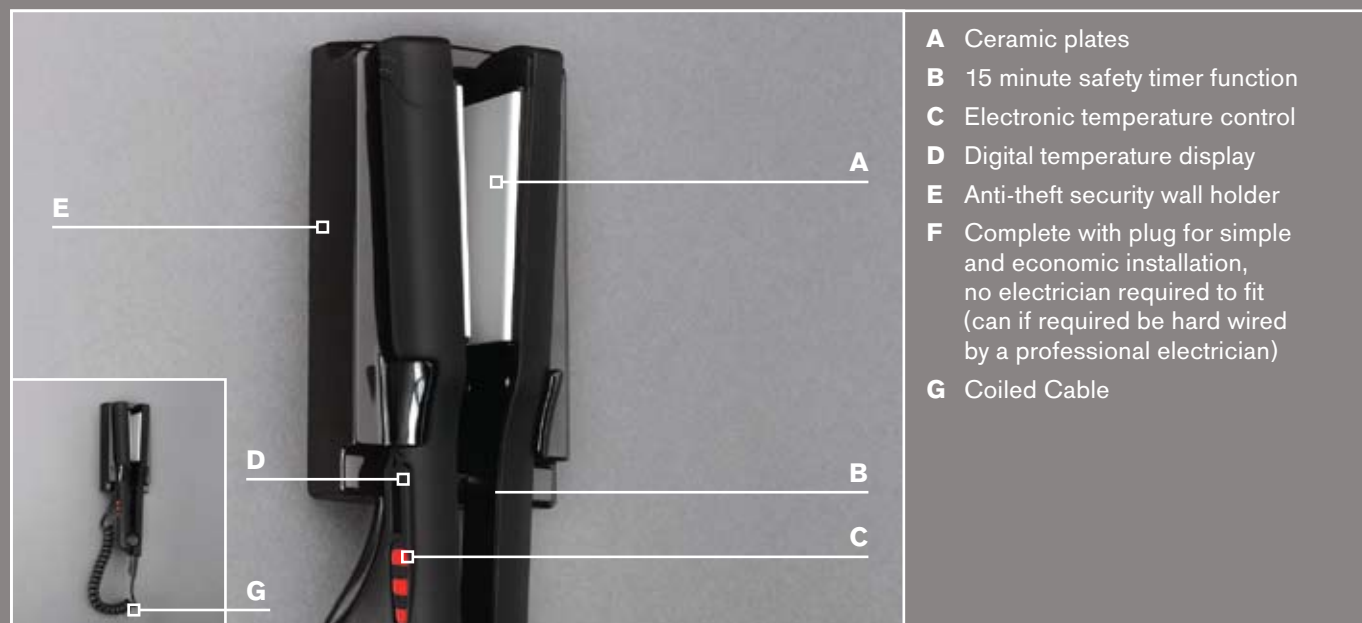

- A** Ceramic plates
- B** 15 minute safety timer function
- C** Electronic temperature control
- D** Digital temperature display
- E** Anti-theft security wall holder
- F** Complete with plug for simple and economic installation, no electrician required to fit (can if required be hard wired by a professional electrician)
- G** Coiled Cable

2 years guarantee

Black

## Elegance Bedroom Ironing Centre (Steam)

The luxury solution to in-room guest ironing

Product code: EICS

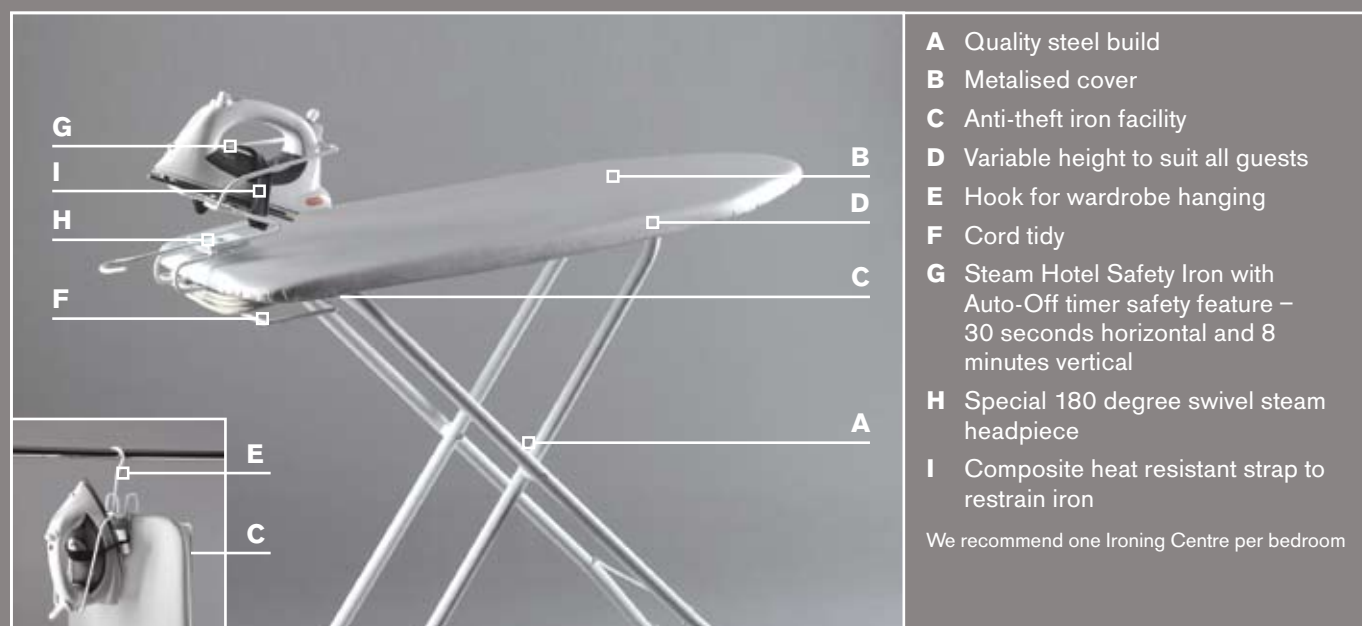

- A** Quality steel build
- B** Metalised cover
- C** Anti-theft iron facility
- D** Variable height to suit all guests
- E** Hook for wardrobe hanging
- F** Cord tidy
- G** Steam Hotel Safety Iron with Auto-Off timer safety feature – 30 seconds horizontal and 8 minutes vertical
- H** Special 180 degree swivel steam headpiece
- I** Composite heat resistant strap to restrain iron

We recommend one Ironing Centre per bedroom

3 years guarantee

Silver Cover / White Body

## Elegance Bedroom Ironing Centre (Dry)

The favoured and neat solution to in-room guest ironing

Product code: EICD

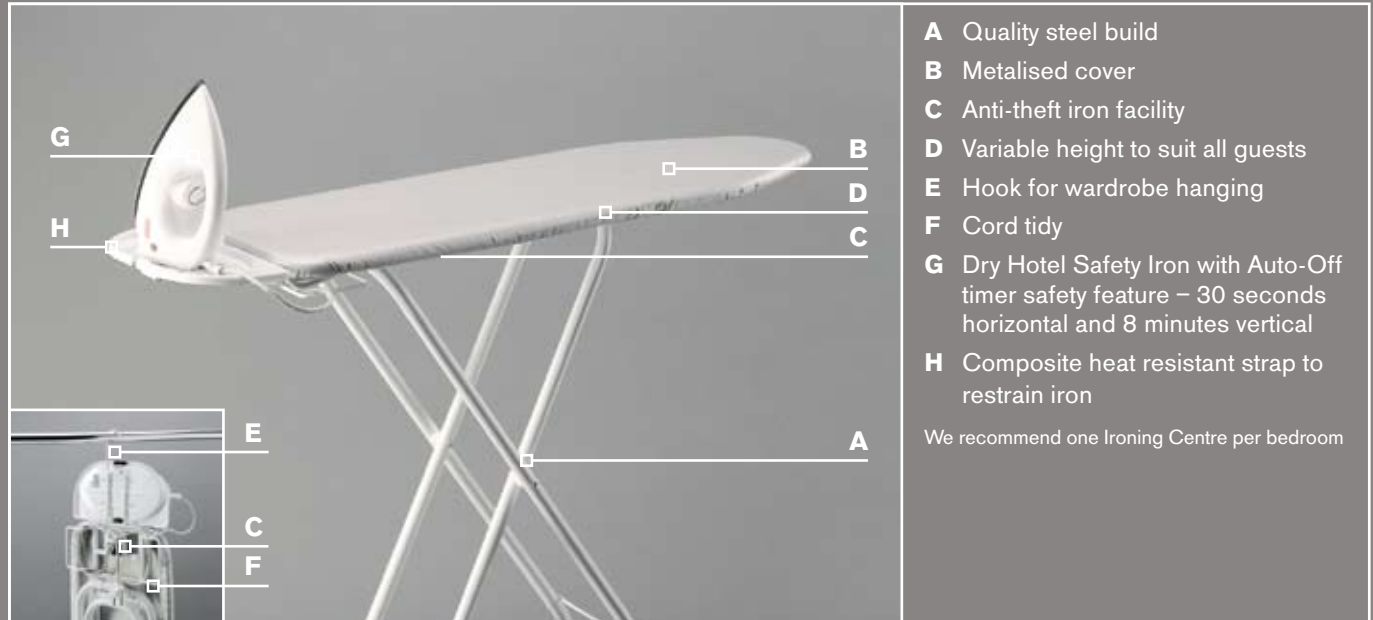

- A** Quality steel build
- B** Metalised cover
- C** Anti-theft iron facility
- D** Variable height to suit all guests
- E** Hook for wardrobe hanging
- F** Cord tidy
- G** Dry Hotel Safety Iron with Auto-Off timer safety feature – 30 seconds horizontal and 8 minutes vertical
- H** Composite heat resistant strap to restrain iron

We recommend one Ironing Centre per bedroom

3 years guarantee

Silver Cover / White Body

## Classic Bedroom Ironing Centre (Steam)

The space saving solution with the luxury of a steam iron

Product code: CICS

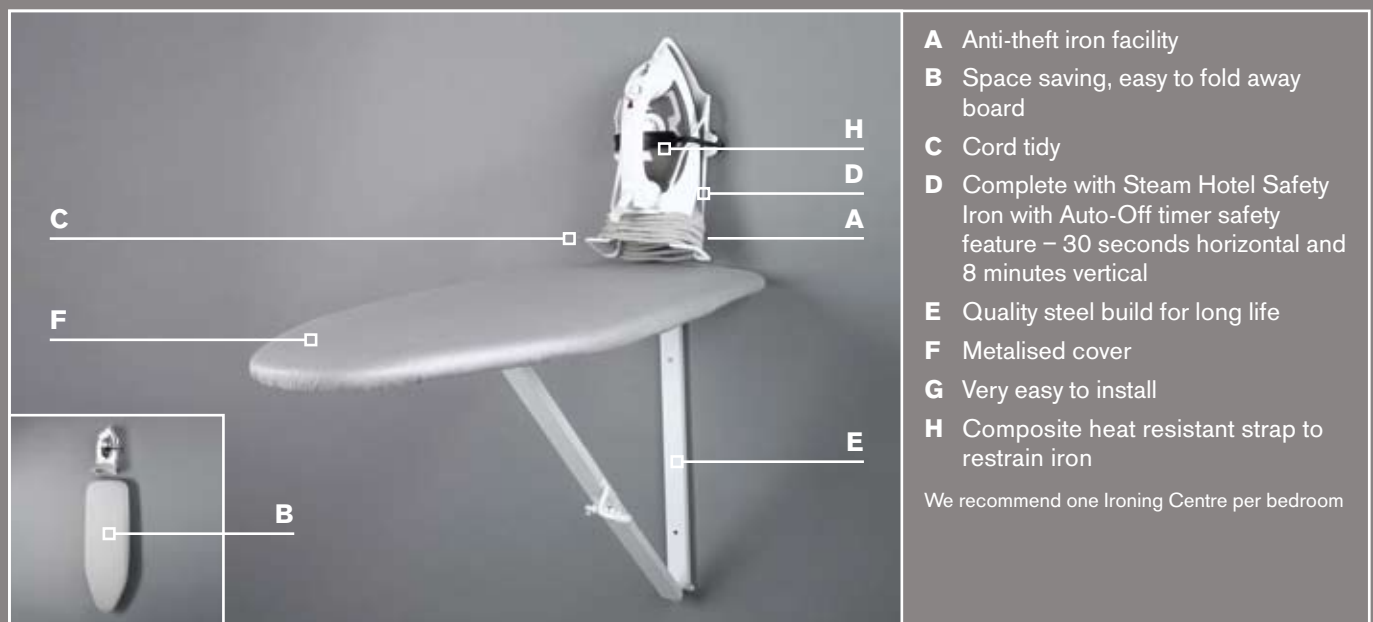

- A** Anti-theft iron facility
- B** Space saving, easy to fold away board
- C** Cord tidy
- D** Complete with Steam Hotel Safety Iron with Auto-Off timer safety feature – 30 seconds horizontal and 8 minutes vertical
- E** Quality steel build for long life
- F** Metalised cover
- G** Very easy to install
- H** Composite heat resistant strap to restrain iron

We recommend one Ironing Centre per bedroom

3 years guarantee

Silver Cover / White Body

# Ironing Centres / Kettles

## Classic Bedroom Ironing Centre (Dry)

For where convenience and space are at a premium

Product code: CICD

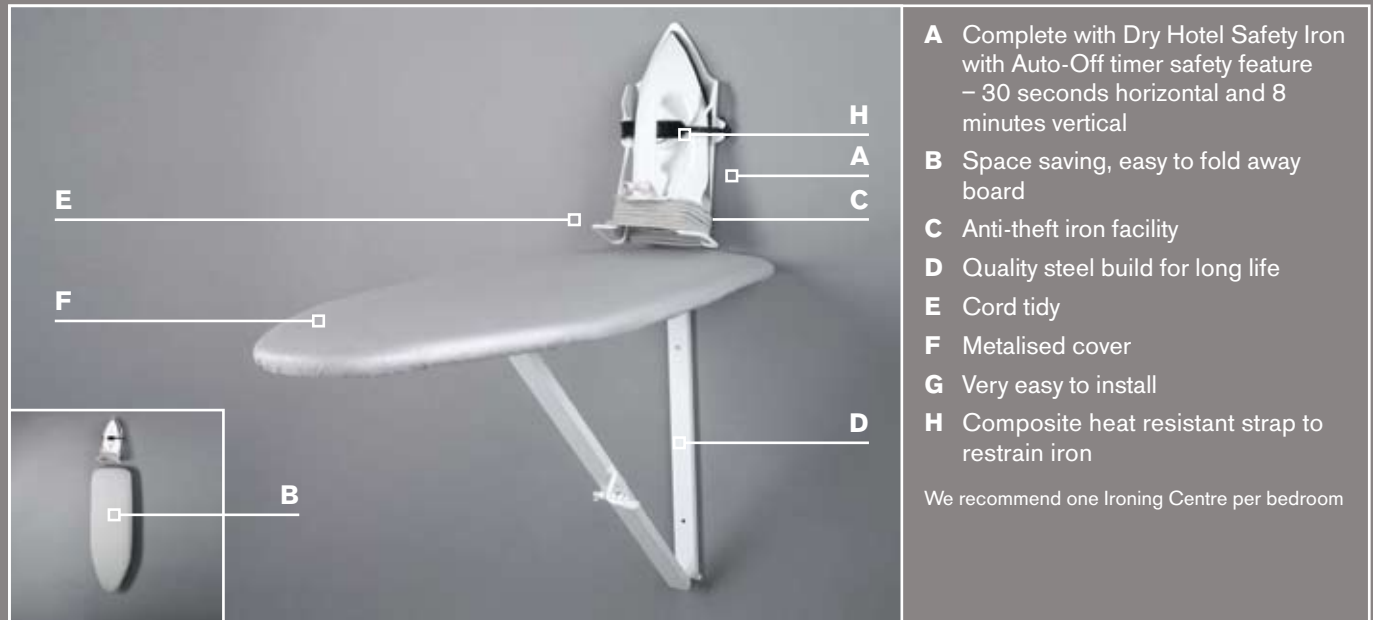

- A** Complete with Dry Hotel Safety Iron with Auto-Off timer safety feature – 30 seconds horizontal and 8 minutes vertical
- B** Space saving, easy to fold away board
- C** Anti-theft iron facility
- D** Quality steel build for long life
- E** Cord tidy
- F** Metalised cover
- G** Very easy to install
- H** Composite heat resistant strap to restrain iron

We recommend one Ironing Centre per bedroom

3 years guarantee

Silver Cover / White Body

## Regal Hotel Kettle

Selected by luxury hotels for its appearance and reliability

Product code: RHK



- A** 1 litre cordless kettle, quick boil, energy saver
- B** Concealed element in stainless steel floor
- C** Auto switch-off with indicator light
- D** 360° base with anti-theft fixing and cord tidy
- E** Safety locking lid
- F** Luxurious chrome finish
- G** Boil dry safety feature
- H** Cool grip handle
- I** Easy for Housekeeping to clean inside kettle

5 years guarantee

Black / Chrome

## President Hotel Kettle

An eco-friendly sized kettle that looks at home in top hotels

Product code: PHK

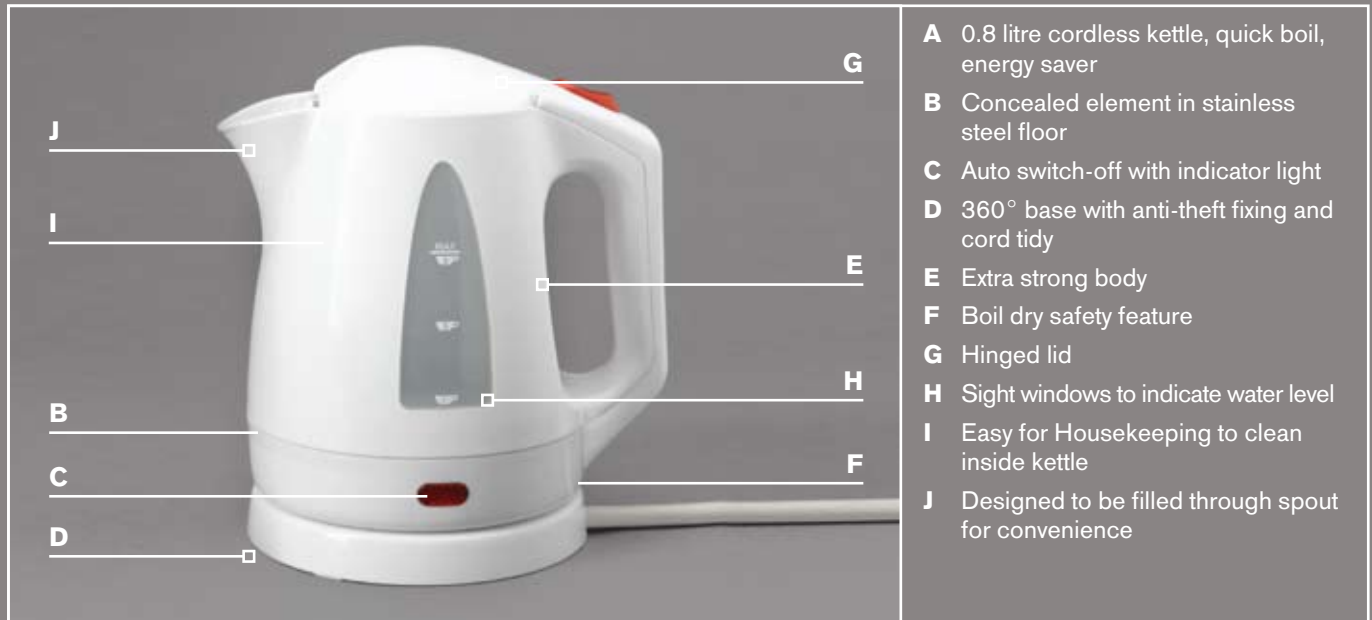

- A** 0.8 litre cordless kettle, quick boil, energy saver
- B** Concealed element in stainless steel floor
- C** Auto switch-off with indicator light
- D** 360° base with anti-theft fixing and cord tidy
- E** Extra strong body
- F** Boil dry safety feature
- G** Hinged lid
- H** Sight windows to indicate water level
- I** Easy for Housekeeping to clean inside kettle
- J** Designed to be filled through spout for convenience

4 years guarantee

Cream or White

## Elegance Hotel Kettle

Appreciated for its design

Product code: EHK

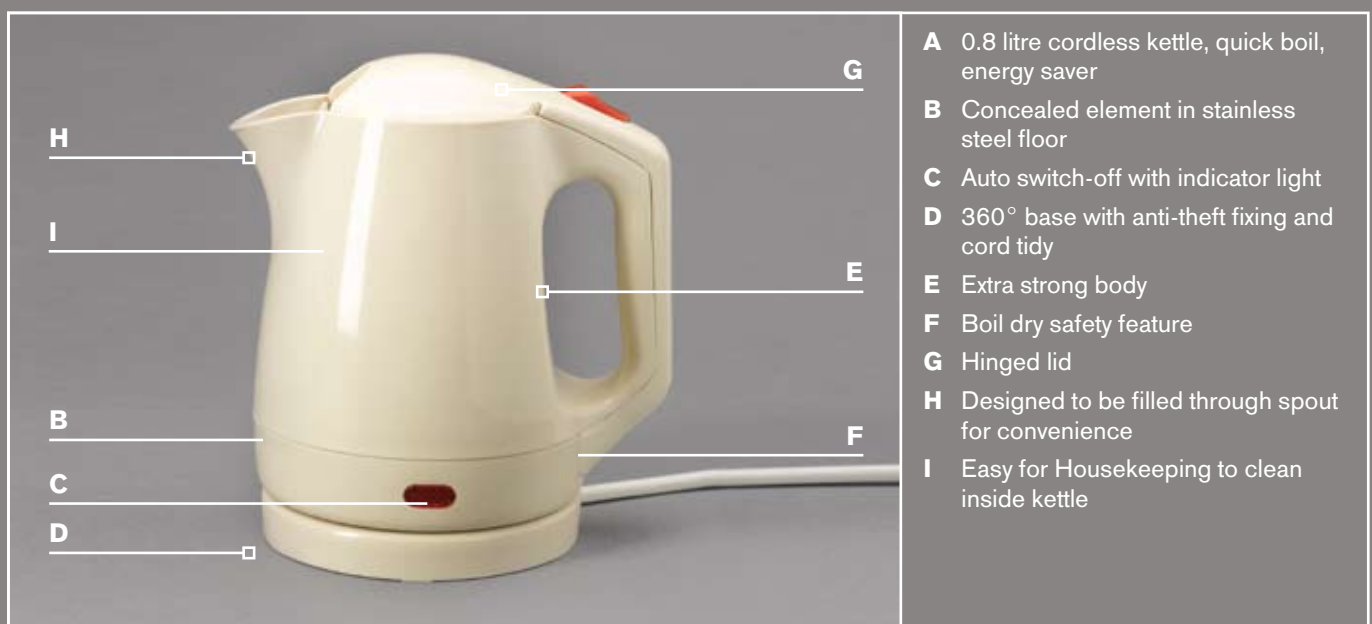

- A** 0.8 litre cordless kettle, quick boil, energy saver
- B** Concealed element in stainless steel floor
- C** Auto switch-off with indicator light
- D** 360° base with anti-theft fixing and cord tidy
- E** Extra strong body
- F** Boil dry safety feature
- G** Hinged lid
- H** Designed to be filled through spout for convenience
- I** Easy for Housekeeping to clean inside kettle

3 years guarantee

Cream or White

# Kettles / Coathangers

## Standard Hotel Kettle

Reliable and economical

Product code: SHK

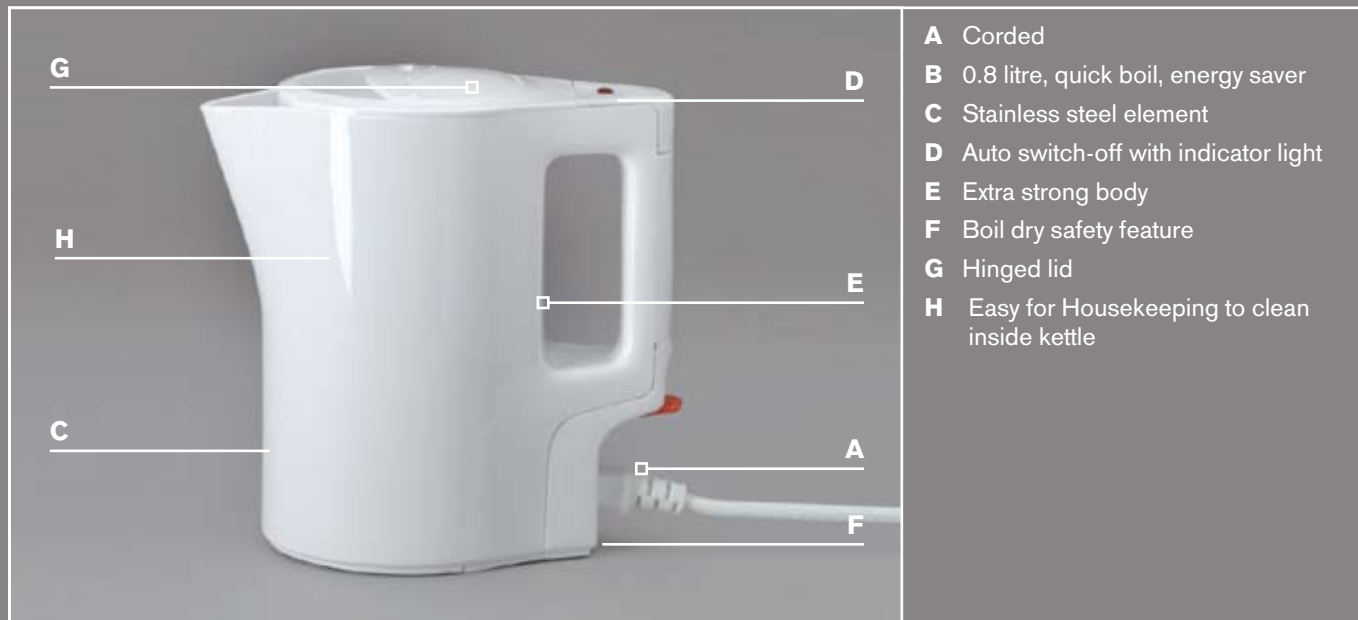

2 years guarantee

White

## Regal Padded Coathanger

Padded luxury for the wardrobe

Product code: RCH

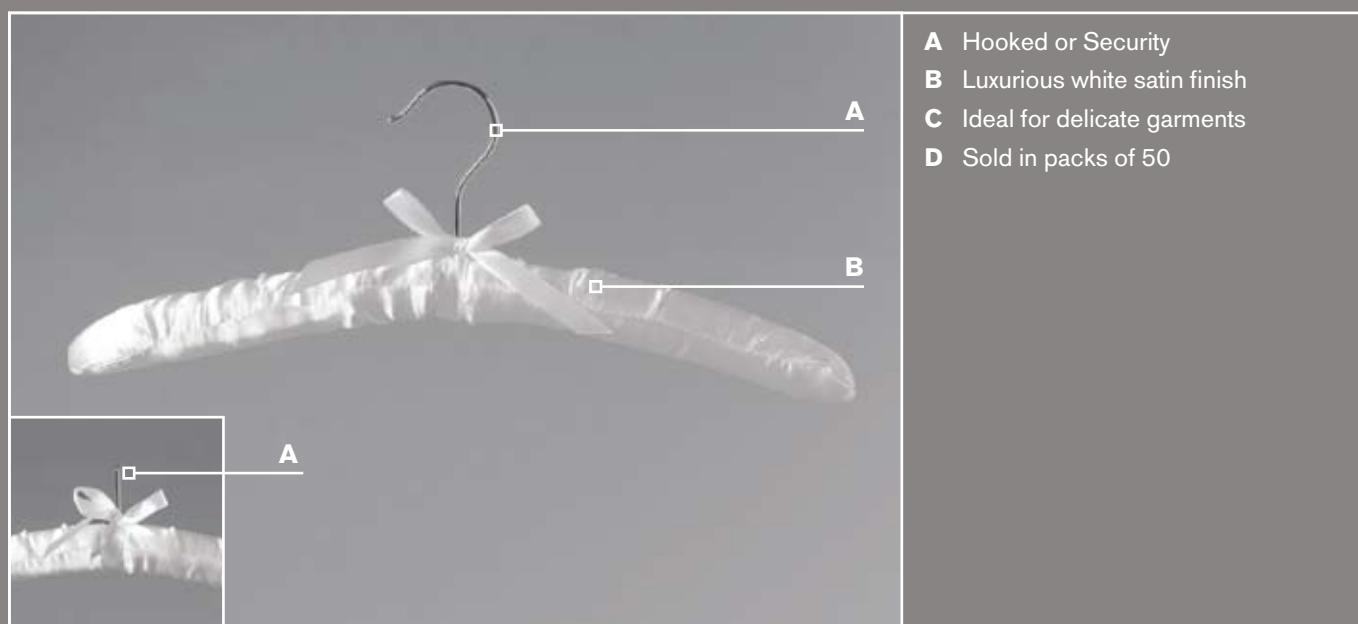

5 years guarantee

Padded. Brass or Chrome Metalwork

## “SuperTuff” Coathanger

For tough environments

Product code: ST

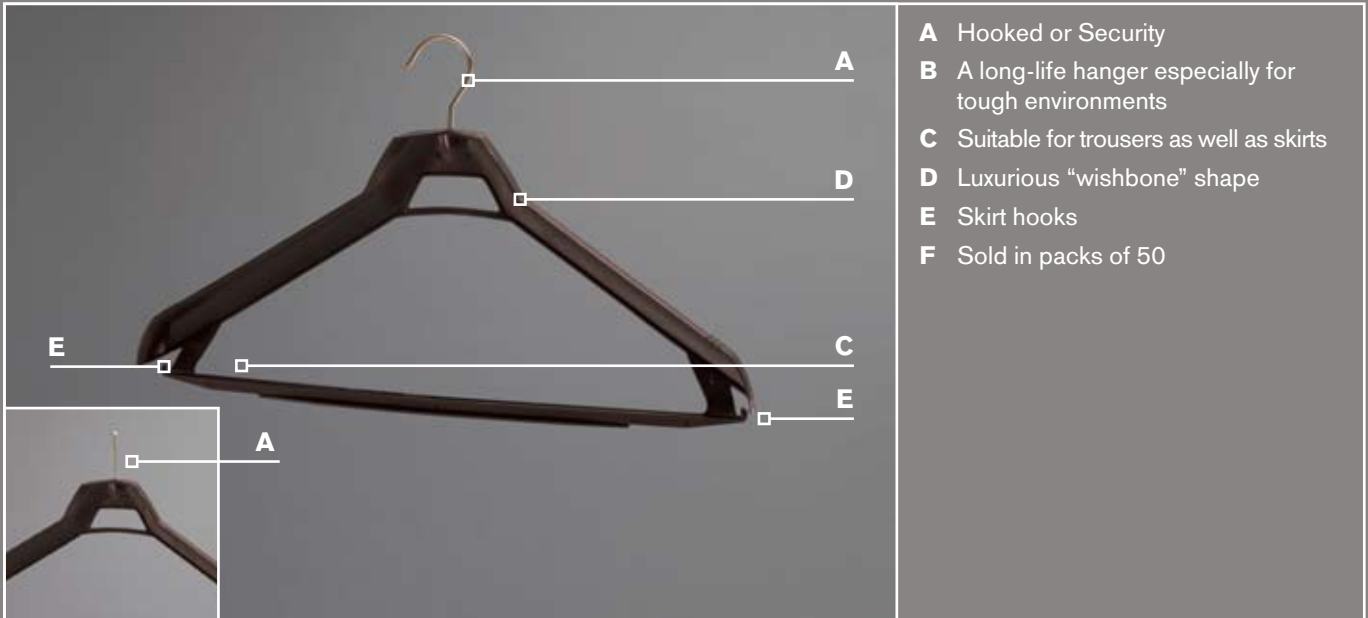

- A** Hooked or Security
- B** A long-life hanger especially for tough environments
- C** Suitable for trousers as well as skirts
- D** Luxurious “wishbone” shape
- E** Skirt hooks
- F** Sold in packs of 50

10 years guarantee

Brown Polypropylene. Brass Metalwork

## President Wooden Coathanger

The timeless classic

Product code: PCH

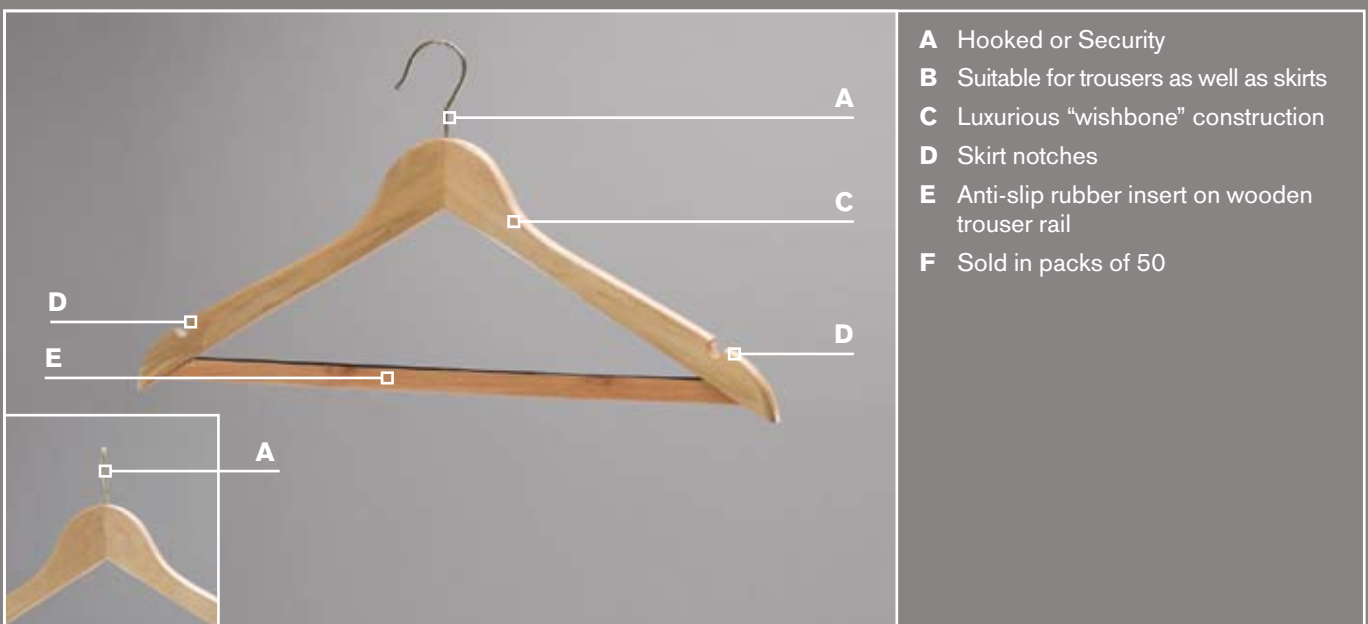

- A** Hooked or Security
- B** Suitable for trousers as well as skirts
- C** Luxurious “wishbone” construction
- D** Skirt notches
- E** Anti-slip rubber insert on wooden trouser rail
- F** Sold in packs of 50

4 years guarantee

Wood. Brass or Chrome Metalwork

# Coathangers

## President Wooden Coathanger with Skirt Clips

A little extra finishing touch in the wardrobe

Product code: PCHJ

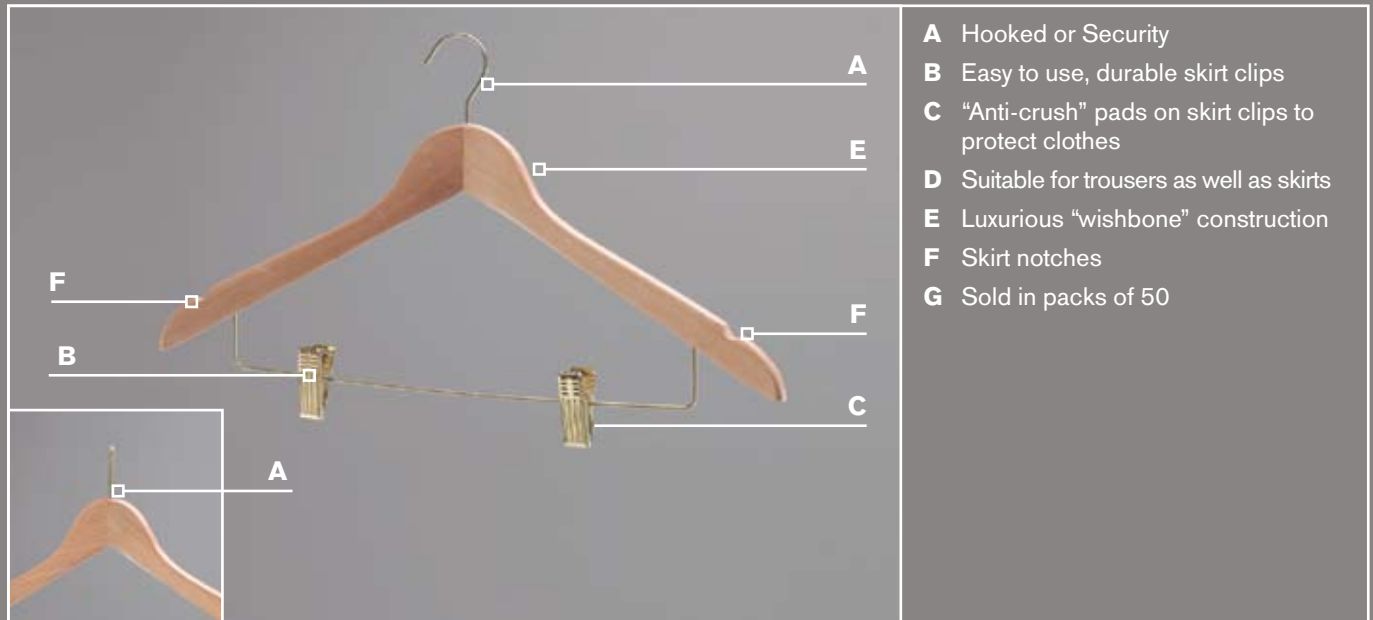

- A** Hooked or Security
- B** Easy to use, durable skirt clips
- C** "Anti-crush" pads on skirt clips to protect clothes
- D** Suitable for trousers as well as skirts
- E** Luxurious "wishbone" construction
- F** Skirt notches
- G** Sold in packs of 50

4 years guarantee

Wood. Brass or Chrome Metalwork

# Security Rings

Practical convenience

Product code: CH2CH (Chrome) / CH2BR (Brass) / CHC1 (Polypropylene)

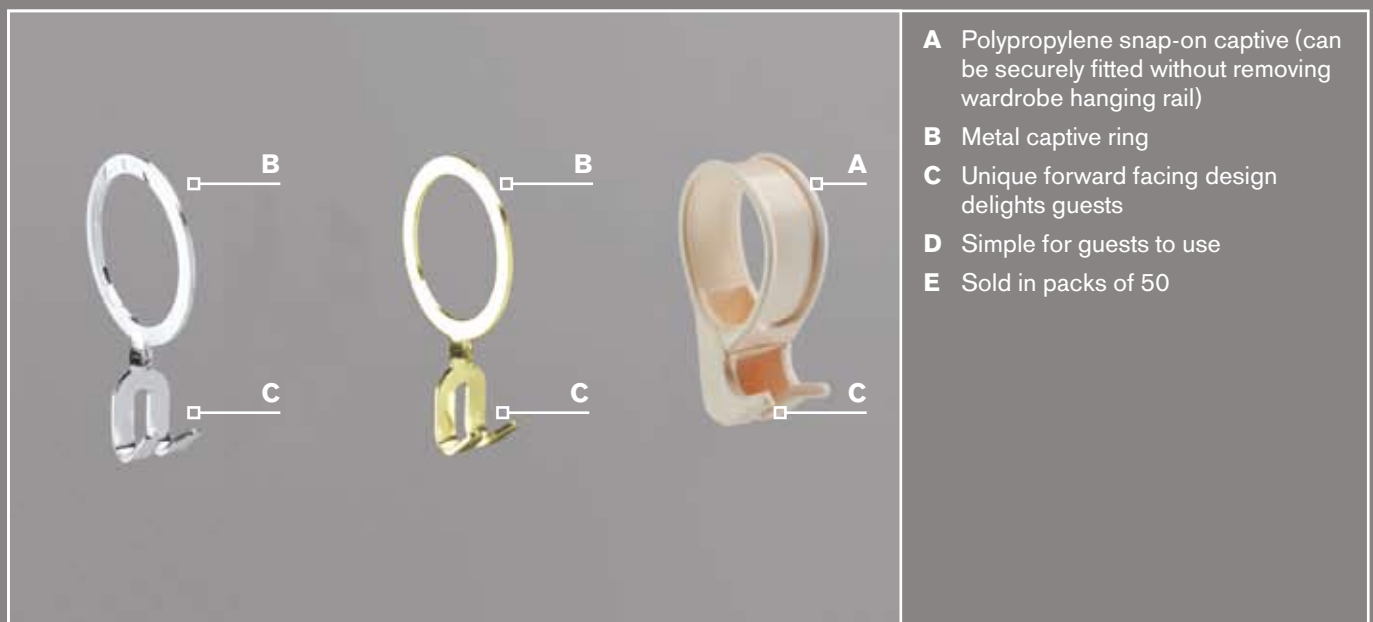

- A** Polypropylene snap-on captive (can be securely fitted without removing wardrobe hanging rail)
- B** Metal captive ring
- C** Unique forward facing design delights guests
- D** Simple for guests to use
- E** Sold in packs of 50

4 years guarantee

Metal: Brass or Chrome Polypropylene: Cream

## Classic Hotel Bedroom Safe

All the special features required in a hotel safe

Product code: PRA

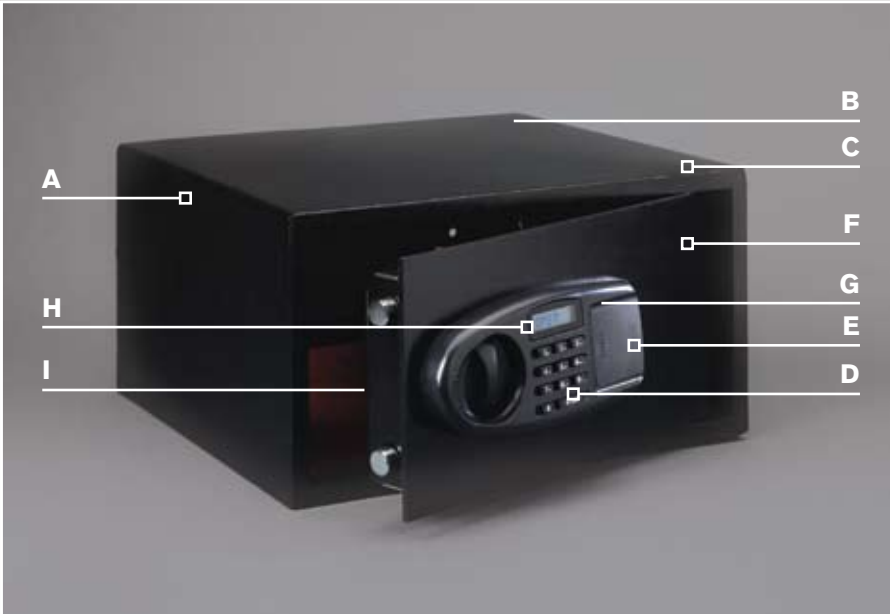

- A** Secure steel construction
- B** Choice of wall and floor fixings with 2 anchor bolts supplied
- C** Large size ideal for most laptops
- D** Reliable electronic controls, with guest 6 digit code for extra security
- E** Emergency external battery access in case of internal battery failure
- F** Disclaimer and instructions on safe door (not illustrated)
- G** Hidden external lock to enable hotel access with emergency security key
- H** Hotel can set its own mastercode for use if guest forgets their code
- I** Internal battery compartment with screw closure to prevent theft of batteries

3 years guarantee

Black

## President Hotel Radio Alarm Clock

The hotel radio alarm clock for top hotels

Product code: PRA

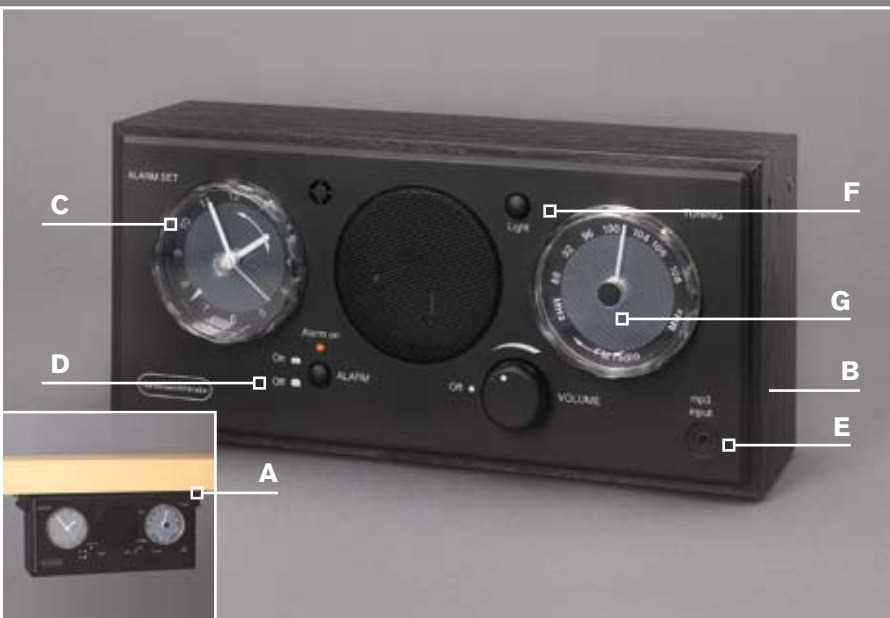

- A** Can be fitted under furniture / shelf, on the wall or used as freestanding unit (with anti-theft fixing)
- B** Hotel can set maximum radio volume
- C** Mains powered but with battery operated clock so clock does not need resetting after mains power interruption
- D** Guest friendly controls with easy to set alarm
- E** MP3 player socket
- F** Back light can be switched on or off
- G** FM radio

4 years guarantee

Black

## Radios / Mirrors

# Elegance Hotel Radio Alarm Clock

Appreciated by guests for its ease of use

Product code: ERA



- A** Guest friendly controls
- B** Easy to set alarm
- C** Digital 24 hour display
- D** Compact space saving design
- E** Anti-theft fixing
- F** AM and FM radio
- G** Mains powered

3 years guarantee

Black

# Classic Guest Mirror

A touch of luxury to pamper your guests

Product code: CGM

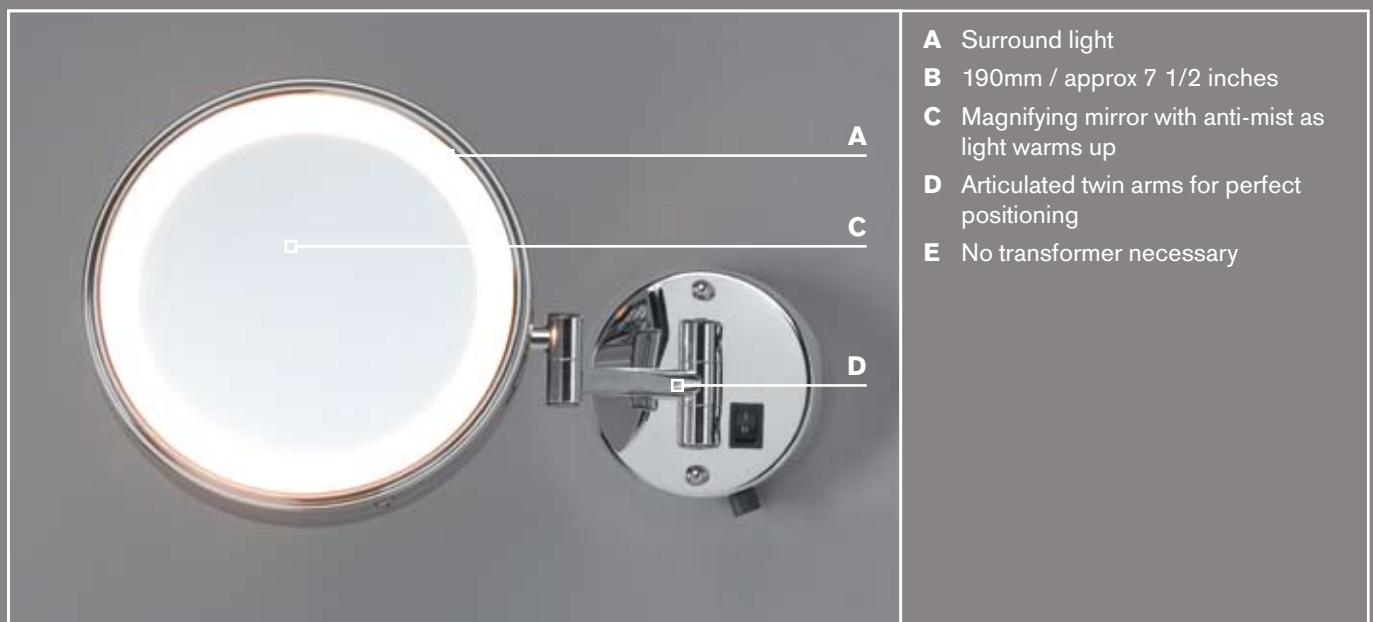

- A** Surround light
- B** 190mm / approx 7 1/2 inches
- C** Magnifying mirror with anti-mist as light warms up
- D** Articulated twin arms for perfect positioning
- E** No transformer necessary

3 years guarantee

Chrome

## Standard Guest Mirror

The necessity appreciated by male and female guests

Product code: SGM

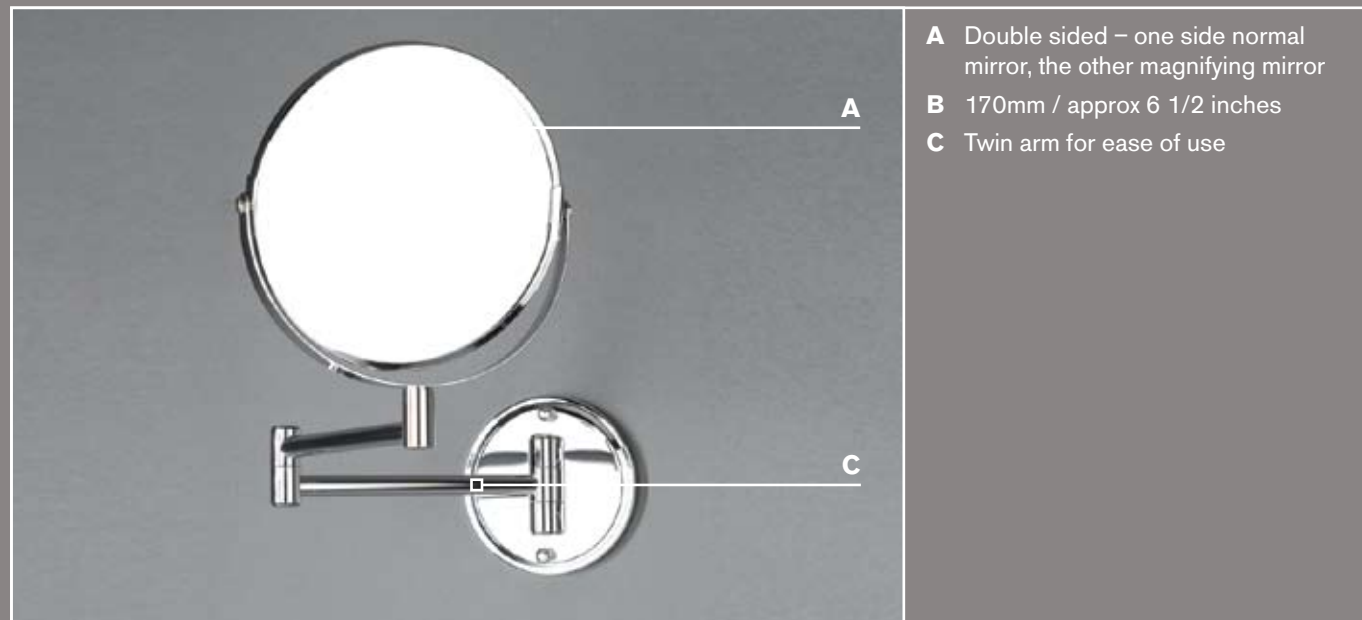

- A** Double sided – one side normal mirror, the other magnifying mirror
- B** 170mm / approx 6 1/2 inches
- C** Twin arm for ease of use

2 years guarantee

Chrome

## President Wastepaper Bin

The attractive solution to waste

Product code: PWB

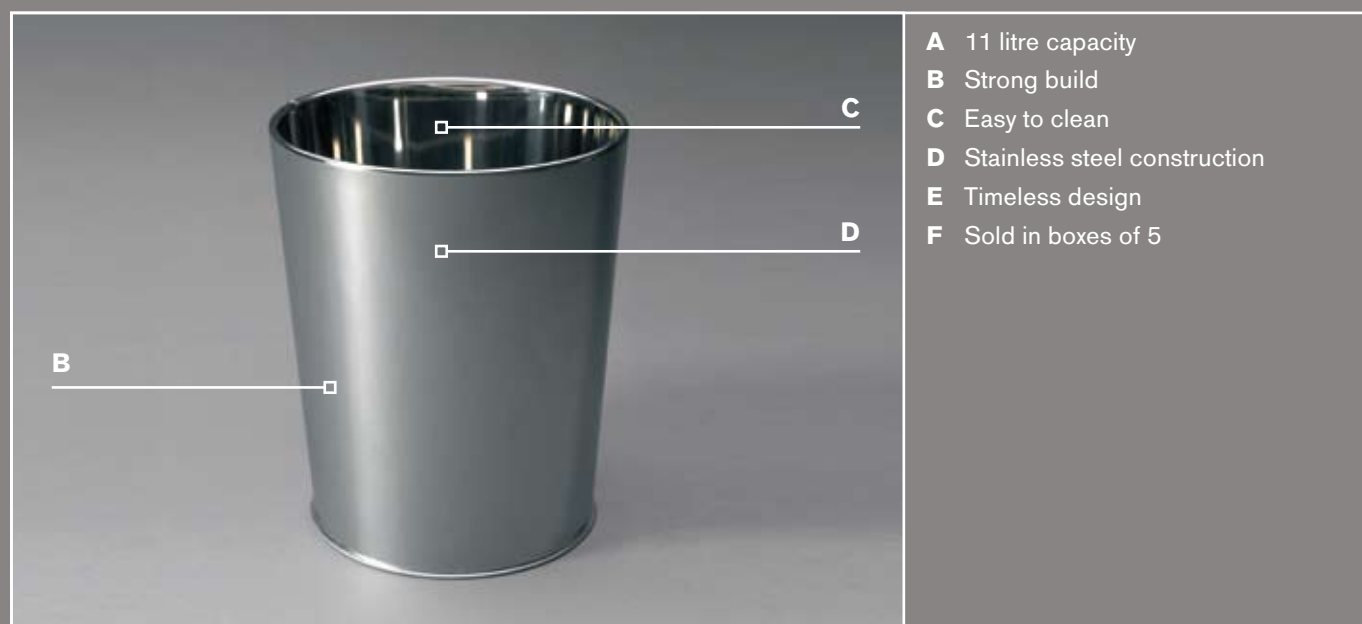

- A** 11 litre capacity
- B** Strong build
- C** Easy to clean
- D** Stainless steel construction
- E** Timeless design
- F** Sold in boxes of 5

4 years guarantee

Stainless Steel (Bright)

# Bins

## Classic Wastepaper Bin

The unobtrusive bin

Product code: CWB

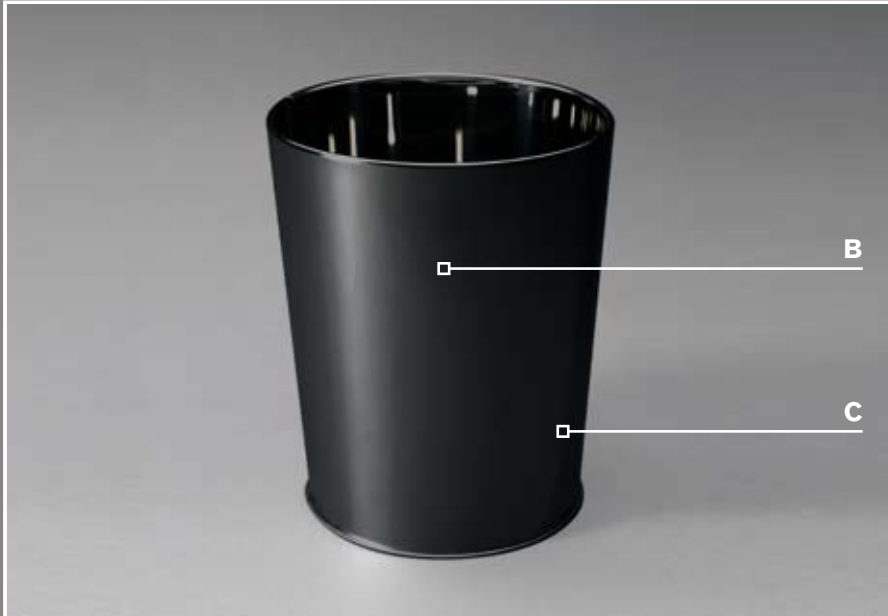

- A** 11 litre capacity
- B** Long life build quality
- C** All steel construction
- D** Sold in boxes of 5

3 years guarantee

Black

## Elegance Pedal Bin

Ideal for bathrooms and toilets

Product code: EPB



- A** Removable and easy to clean plastic inner bucket
- B** Bright stainless steel
- C** Anti-scuff plastic base
- D** 3 litre capacity

3 years guarantee

Stainless Steel (Bright)

## Classic Luggage Rack

The original and still the best

Product code: CLR



- A** Designed by one of the world's top designers
- B** Solid wood
- C** Extra tough webbing
- D** Folds away to save space when not in use

3 years guarantee

Beech or Mahogany Finish

## Elegance Luggage Rack

Attractive timeless design

Product code: ELR



- A** Special back helps stop cases from damaging the wall
- B** Extra tough webbing
- C** Folds away to save space when not in use
- D** Thick steel legs

3 years guarantee

Chrome

# Luggage Racks / Irons

## Standard Luggage Rack

The favourite with hotels worldwide

Product code: SLR



- A** Extra tough webbing
- B** Folds away to save space when not in use
- C** Timeless design
- D** Thick steel legs

2 years guarantee

Chrome

## Elegance Hotel Safety Iron (Steam)

The ultimate hotel iron for guest use

Product code: ESI



- A** Guest friendly controls
- B** Stainless steel sole plate, "easy-glide" non-stick
- C** Integral Hotel Auto-Off timer safety feature – 30 seconds horizontal and 8 minutes vertical
- D** Shot of steam and spray facilities
- E** Self-clean feature
- F** Protective safety cut-out

3 years guarantee

White

## Elegance Hotel Safety Iron (Dry)

The safe and easy choice for guests

Product code: EDI

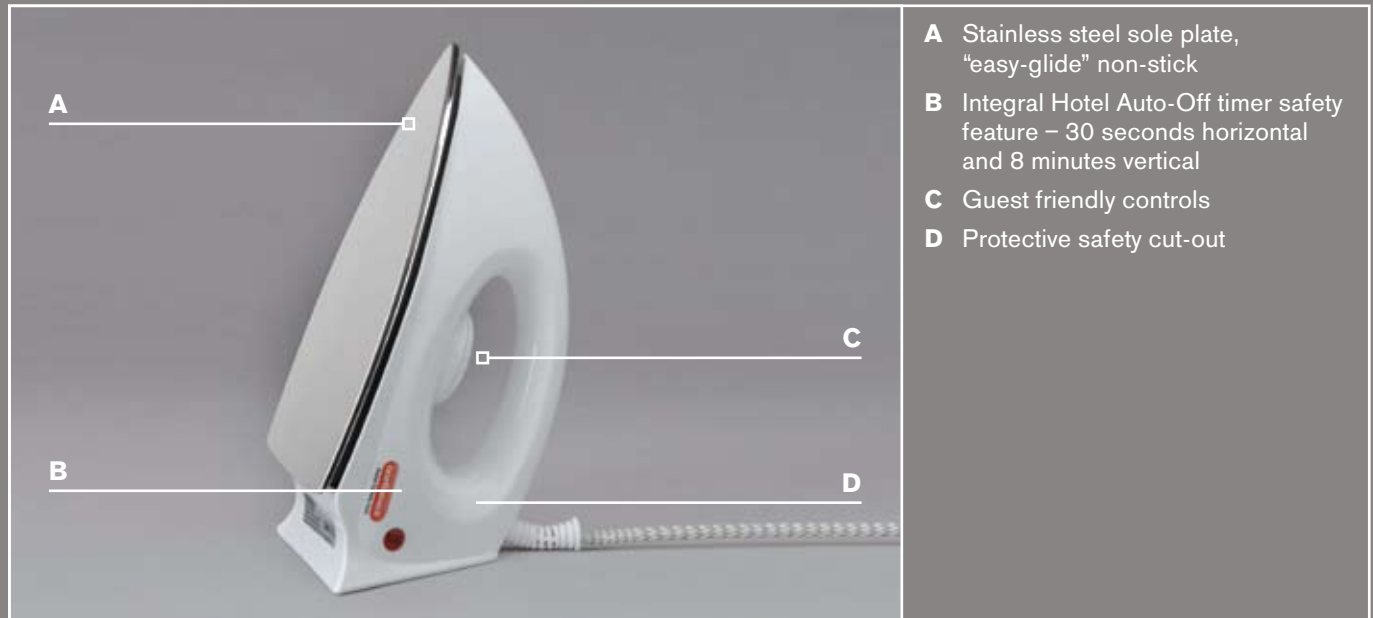

- A** Stainless steel sole plate, "easy-glide" non-stick
- B** Integral Hotel Auto-Off timer safety feature – 30 seconds horizontal and 8 minutes vertical
- C** Guest friendly controls
- D** Protective safety cut-out

3 years guarantee

White

## Classic Iron Store

The professional solution for iron storage

Product code: CIHU

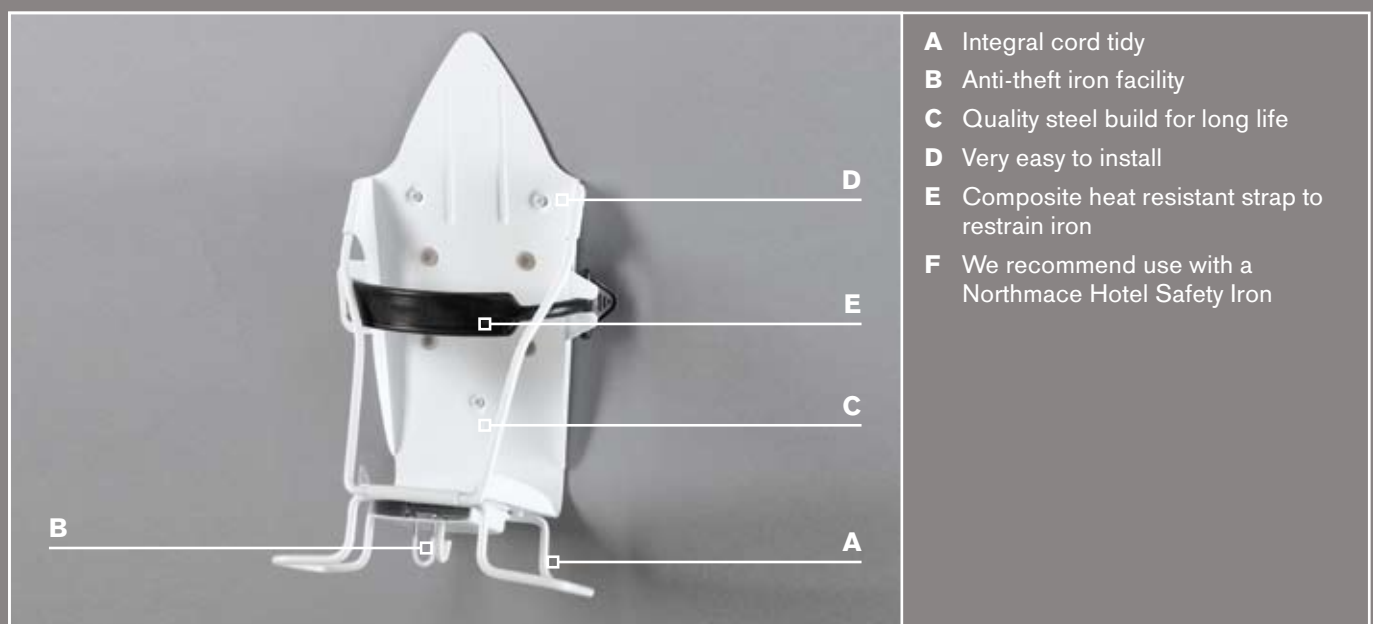

- A** Integral cord tidy
- B** Anti-theft iron facility
- C** Quality steel build for long life
- D** Very easy to install
- E** Composite heat resistant strap to restrain iron
- F** We recommend use with a Northmace Hotel Safety Iron

3 years guarantee

White

# Bathroom & Washroom

## Hotel Rubber Bath / Shower Mat

Very popular with housekeepers

Product code: BMW



- A** Anti-slip with safety sucker pads
- B** Textured surface with anti-mildew treatment
- C** Machine washable
- D** Use on non-textured flat surface only
- E** Sold in packs of 10

1 year guarantee

White

## Hotel Shower Curtain

Luxurious look in every bathroom at an attractive price

Product code: SCW (1800mm x 1800mm) / SCWL (1800mm x 2000mm)



- A** Satin stripe white polyester
- B** Machine washable
- C** Reinforced non-rust eyelets
- D** Complete with 12 free plastic hooks
- E** Water-resistant, anti-mildew treated
- F** Weighted bottom hem
- G** Sold in packs of 10

1 year guarantee

White with Satin Stripe. SCW (1800mm x 1800mm) SCWL (1800mm x 2000mm)

# Wrapped Disposable Tumblers

Hygienic and appreciated by guests

Product code: WDT



- A** Hygienic
- B** Individually wrapped
- C** Reduces room cleaning time
- D** Recyclable
- E** Saves time and money
- F** 9 fl oz
- G** Ideal for the bathroom
- H** Sold in packs of 1,000

# Hygiene Bags Refills

Convenient and professional solution

Product code: HBR



- A** Helps prevent unnecessary wastage
- B** Easy to store and manage
- C** Each refill contains 25 individual bags
- D** Fits most holders
- E** Sold in packs of 100 refills

## Technical Information

For technical information please visit our website.

## Environment

As a global company, Northmace & Hendon is aware of its responsibility to ensure sustainable and environmentally positive business practices as detailed in the Environmental Management Standard ISO 14001.

The company seeks to minimise waste, maximise recycling and conserve resources.

Northmace & Hendon complies with the European Directive on Waste Electrical and Electronic Equipment.

Northmace & Hendon also look to design products that minimise the environmental impact.

All the company's products comply with the European Directive on the Restriction of Hazardous Substances.

**Wherever appropriate, recyclable materials are used.**



Environmentally  
Conscious  
Organisation

Distributed by:

**Northmace&Hendon**<sup>TM</sup>

ESTD LONDON 1942

[www.northmace.com](http://www.northmace.com)

Northmace & Hendon Limited, Northmace House, Viaduct Road, Cardiff, UK, CF15 9XF  
UK Sales: 029 2081 5200 Fax: 029 2081 3275 International Sales: +44 29 2081 5200 International Fax: +44 29 2081 3275  
email: [sales@northmace.com](mailto:sales@northmace.com)

Title to the goods does not pass until all monies due to Northmace & Hendon Limited have been paid. Crockery, ingredients, batteries etc not supplied. Please note that the buyer acknowledges and accepts that it shall have sole responsibility for the disposal, recovery and reuse of any goods or products comprising electrical and electronic products including without limitation any goods provided and any goods to which the Waste Electrical and Electronic Equipment Directive (or any legislation implementing such Directive) relates and the buyer shall be solely responsible for any costs incurred as a result of this. The buyer hereby agrees to indemnify Northmace & Hendon Limited in accordance with the provisions of condition 11 of our Standard Terms and Conditions in respect of any failure to comply with this condition. Products are protected by worldwide design registration and patents. Our policy of continuous development means that specifications may change without prior notice and certain products may no longer be available. Please check any critical details with our Sales Department before ordering. Actual colours may vary from those printed. Subject to Northmace & Hendon Limited's Standard Terms and Conditions (available on request and on [www.northmace.com](http://www.northmace.com)), © Northmace & Hendon Limited 2009